

Curb Base



Model Shown:
CB 1250 FT

Curb Base Model Application:

For installation on any low slope or commercial flat roof.

Available Curb Base Models:

SunRise 1250 FT - 30 Watt - For areas up to 2000 sq. ft.

SunRise 1650 FT - 45 Watt - For areas up to 2800 sq. ft.

The SunRise® Attic Fan Curb Base Model

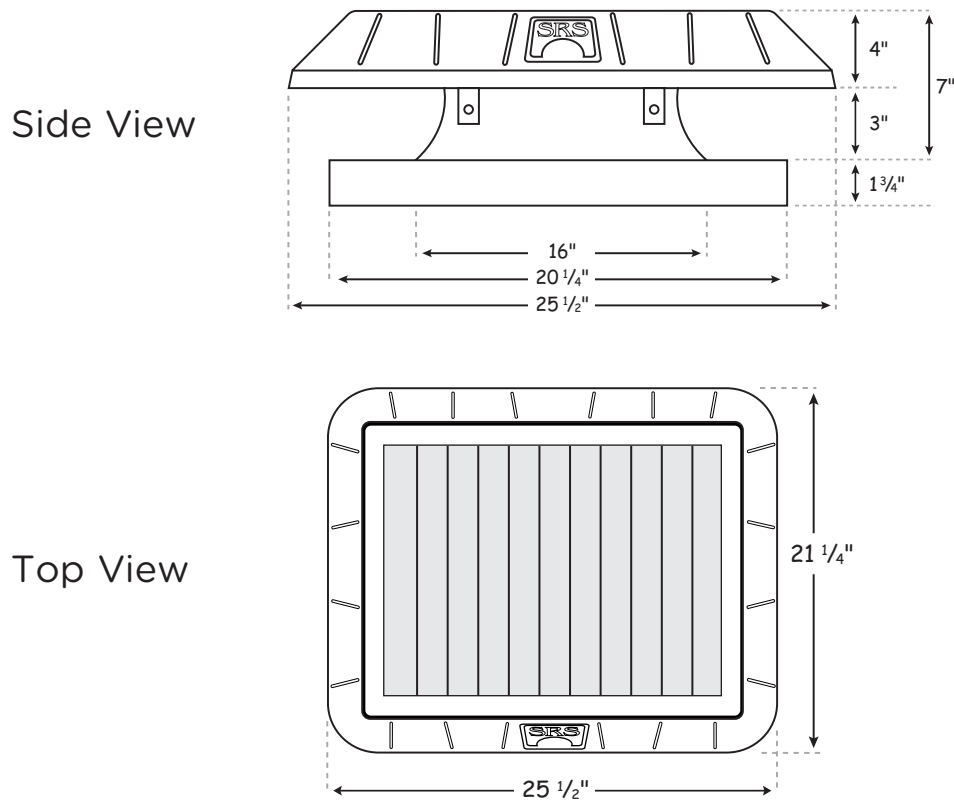

Features:

- | | |
|--|--|
| <p>Solar Panel: Impact resistant crystalline with tempered glass surface</p> <p>Motor: Ultra quiet, brushless DC motor</p> <p>Wire: 18/2 red/black</p> <p>Fan Blade: 12" diameter, 5-blade poly-carbon, computer balanced hub</p> <p>Hardware: ALL stainless steel fasteners, including welded stainless steel screen</p> <p>Top and Base: UV-Stabilized ABS composite (paintable)</p> <p>Airflow: The more intense the sun shines, the faster the SunRise runs</p> <p>Thermostat: Turns fan on at 80° and off at 65° during daylight hours</p> <p>Warranty: 25 Year Limited Warranty</p> | <p>Unit Dimensions: Height 7", Top 25.5" x 21.25"</p> <p>Base Size: 20.25" x 20.25"</p> <p>Unit Weight: 16 lbs.</p> <p>Shipping Weight: 18 lbs.</p> <p>Package Size: 27.25" x 25.5" x 11.25" wide.</p> <p>Available Models: CB 1250 FT
CB 1650 FT
CB 1650 TLT FT</p> |
|--|--|