

Flat Base



Model Shown:
FB 1250 FT

Flat Base Model Application:

For installation on any normal pitched shingled roof, where south or west exposure is available.

Available Flat Base Models:

SunRise 1250 FT - 30 Watt - For areas up to 2000 sq. ft.

SunRise 1650 FT - 45 Watt - For areas up to 2800 sq. ft.



Model Shown:
FB 1650 FT

The SunRise® Attic Fan Flat Base Model

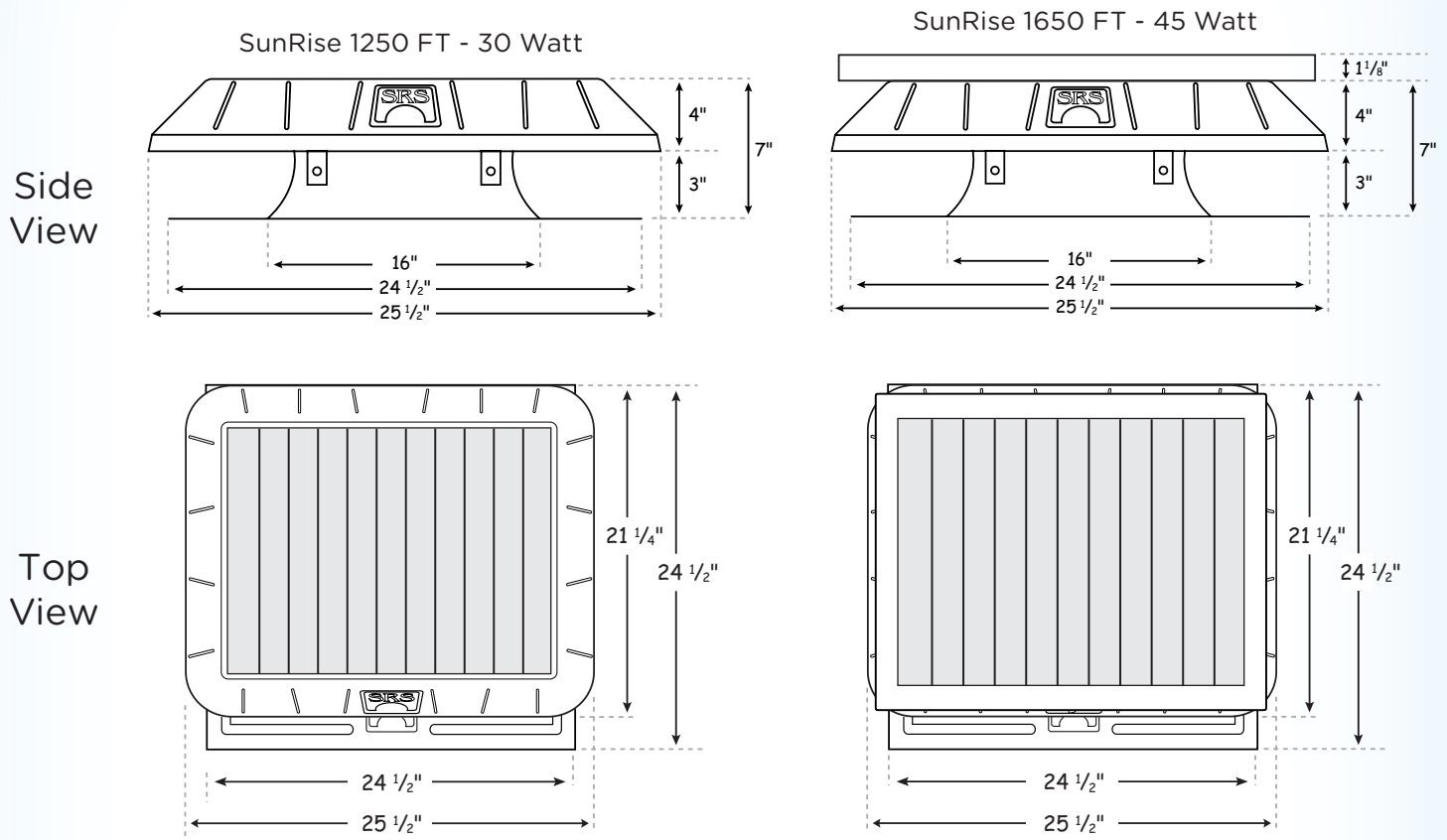

Features:

- Solar Panel:** Impact resistant crystalline with tempered glass surface
- Motor:** Ultra quiet, brushless DC motor
- Wire:** 18/2 red/black
- Fan Blade:** 12" diameter, 5-blade poly-carbon, computer balanced hub
- Hardware:** ALL stainless steel fasteners, including welded stainless steel screen
- Top and Base:** UV-Stabilized ABS composite (paintable)
- Airflow:** The more intense the sun shines, the faster the SunRise runs
- Thermostat:** Turns fan on at 80° and off at 65° during daylight hours
- Warranty:** 25 Year Limited Warranty

FB 1250 FT

Unit Dimensions: Height 7", Top 25.5" x 21.25"

Base Size: 24.5" x 24.5"

Unit Weight: 17 lbs

Shipping Weight: 19 lbs

Package Size: 27.25" x 25.5" x 11.25" wide

FB 1650 FT

Unit Dimensions: Height 8.25", Top 25.5" x 21.25"

Base Size: 24.5" x 24.5"

Unit Weight: 21 lbs

Shipping Weight: 23 lbs

Package Size: 27.25" x 25.5" x 11.25" wide