

Remote Panel



Model Shown:
FB 1250 RP FT

Remote Panel Model Application:

For installation on any normal pitched shingled roof, where south or west exposure is not available.

Available Remote Panel Models:

SunRise 1250 FT - 30 Watt - For areas up to 2000 sq. ft.

SunRise 1650 FT - 45 Watt - For areas up to 2800 sq. ft.

The SunRise® Attic Fan Remote Panel Model

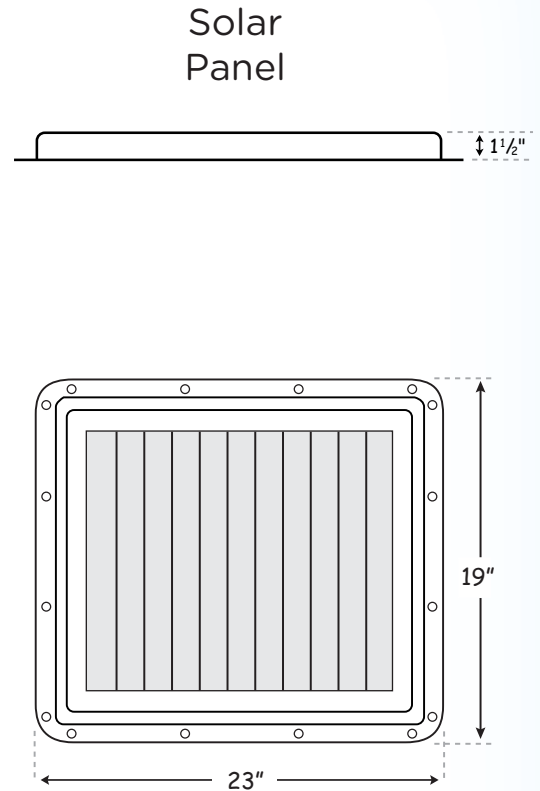
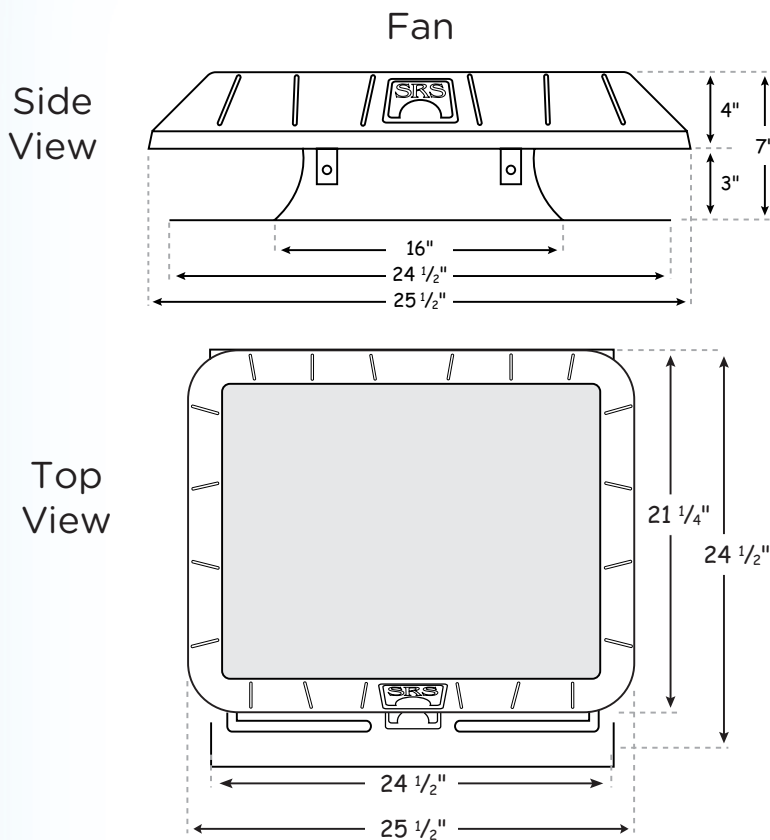

Features:

Solar Panel: Impact resistant crystalline with tempered glass surface in self-flashing composite mounting tray

Motor: Ultra quiet, brushless DC motor

Wire: 18/2 red/black

Fan Blade: 12" diameter, 5-blade poly-carbon, computer balanced hub

Hardware: ALL stainless steel fasteners, including welded stainless steel screen

Top and Base: UV-Stabilized ABS composite (paintable)

Airflow: The more intense the sun shines, the faster the SunRise runs

Panel Dimensions: Height 1.5", Top 24" x 23"

Thermostat: Turns fan on at 80° and off at 65° during daylight hours

Warranty: 25 Year Limited Warranty

Fan Dimensions: Height 7", Top 24" x 24"

Base Size: 24.5" x 24.5".

Unit Weight: 20 lbs.

Shipping Weight: 22 lbs.

Package Size: 27.25" x 25.5" x 11.25" wide.

Available Models: FB 1250 RP FT

FB 1650 RP FT[†]

[†] 1650 model has aluminum framed solar panel and (4) aluminum "L" brackets for mounting the panel to the roof